

**General Information** Quick Selection Guide ..... page 10-2

**DeviceNet Sensors** RightSight™ DeviceNet ..... page 10-4

SmartSight™ 9000 DeviceNet ..... page 10-8

Inductive Proximity  
DeviceNet ..... page 10-12



Limit Switch DeviceNet ..... page 10-14



Encoder DeviceNet ..... page 10-16

**Indexes** Cat. No. Index ..... page 13-1

Comprehensive Product Index ..... page 14-1

## Quick Selection Guide

<p><b>Specifications</b></p>	 <p><b>RightSight™</b> Photoelectric Sensor</p>	 <p><b>SmartSight™ 9000</b> Photoelectric Sensor</p>	 <p><b>871TM</b> Inductive Proximity Sensor</p>
<p><b>Features</b></p>	<ul style="list-style-type: none"> <li>• DeviceNet Network compatibility</li> <li>• Patented 18 mm housing design with 1200 psi washdown rating</li> <li>• Selectable COS/Strobe</li> <li>• Advanced diagnostics, counter, and timers</li> </ul>	<ul style="list-style-type: none"> <li>• DeviceNet Network compatibility</li> <li>• Harsh duty 30 mm housing</li> <li>• 1200 psi washdown</li> <li>• Advanced features such as teach, selectable COS/Strobe, counter, timers and diagnostics</li> </ul>	<ul style="list-style-type: none"> <li>• DeviceNet Network compatibility, stainless steel face and barrel, 1200 psi washdown rated, standard mounting, discrete or analog output, timing options, advanced diagnostics</li> </ul>
<p><b>Output Type</b></p>	<ul style="list-style-type: none"> <li>• DeviceNet</li> </ul>	<ul style="list-style-type: none"> <li>• DeviceNet</li> </ul>	<ul style="list-style-type: none"> <li>• DeviceNet</li> </ul>
<p><b>Connections</b></p>	<ul style="list-style-type: none"> <li>• 5-pin DC micro QD</li> </ul>	<ul style="list-style-type: none"> <li>• 5-pin DC micro QD</li> <li>• 5-pin mini QD</li> <li>• 2 m cable</li> </ul>	<ul style="list-style-type: none"> <li>• 5-pin DC micro QD</li> <li>• 5-pin mini QD</li> <li>• 2 m CPE cable</li> </ul>
<p><b>Available Models</b></p>	<ul style="list-style-type: none"> <li>• Polarized Retroreflective . . . . . 10-6</li> <li>• Standard Diffuse . . . . . 10-6</li> <li>• Sharp Cutoff Diffuse . . . . . 10-6</li> <li>• Background Suppression . . . . . 10-6</li> <li>• Infrared Fiber Optic . . . . . 10-7</li> <li>• Transmitted Beam . . . . . 10-7</li> </ul>	<ul style="list-style-type: none"> <li>• Retroreflective . . . . . page 10-10</li> <li>• Polarized Retroreflective . . . . . page 10-10</li> <li>• ClearSight™ . . . . . page 10-10</li> <li>• Standard Diffuse . . . . . page 10-11</li> <li>• Infrared Glass Fiber Optic . . . . . page 10-11</li> <li>• Visible Red Glass Fiber Optic . . . . . page 10-11</li> <li>• Transmitted Beam . . . . . page 10-11</li> </ul>	<ul style="list-style-type: none"> <li>• 18 mm shielded . . . . . 10-12</li> <li>• 18 mm unshielded . . . . . 10-12</li> <li>• 30 mm shielded . . . . . 10-12</li> <li>• 30 mm unshielded . . . . . 10-12</li> </ul>
<p><b>Additional Info</b></p>	<ul style="list-style-type: none"> <li>• See page 10-4</li> </ul>	<ul style="list-style-type: none"> <li>• See page 10-8</li> </ul>	<ul style="list-style-type: none"> <li>• See page 10-12</li> </ul>

<p><b>Specifications</b></p>	 <p><b>802DN</b> Limit Switch</p>	 <p><b>842D</b> Encoder</p>
<p><b>Features</b></p>		<ul style="list-style-type: none"> <li>• DeviceNet Network compatibility, advanced diagnostics</li> </ul>
<p><b>Output Type</b></p>	<ul style="list-style-type: none"> <li>• DeviceNet</li> </ul>	<ul style="list-style-type: none"> <li>• DeviceNet</li> </ul>
<p><b>Connections</b></p>	<ul style="list-style-type: none"> <li>• 5-pin DC micro QD</li> <li>• 5-pin mini QD</li> <li>• 2 m CPE cable</li> </ul>	<ul style="list-style-type: none"> <li>• 5-pin DC micro QD</li> </ul>
<p><b>Available Models</b></p>	<ul style="list-style-type: none"> <li>• Limit Switch without lever . . . . . 10-14</li> <li>• Limit Switch with wide belt roller . . . . . 10-14</li> </ul>	<ul style="list-style-type: none"> <li>• 26-bit absolute multi-turn . . . . . 10-16</li> </ul>
<p><b>Additional Info</b></p>	<ul style="list-style-type: none"> <li>• See page 10-14</li> </ul>	<ul style="list-style-type: none"> <li>• See page 10-16</li> </ul>



**Description**

Rockwell Automation/Allen-Bradley DeviceNet sensors interface directly to this industry-standard plant floor network without the need for additional I/O blocks or adaptors. In addition to the standard On/Off indication, DeviceNet compatible sensors provide advanced logic and diagnostic functions not available in competitive DeviceNet models. Logic functions include counters, timers and motion detection; the diagnostics warn of unstable application characteristics. For example, the 871™ DeviceNet proximity sensor will produce a diagnostic output when the target is too close to the sensor face or at the outside edge of the sensing range. Further, Allen-Bradley DeviceNet sensors may be configured for either strobing or change-of-state (COS) operating modes, normally open or normally closed outputs (light operate or dark operate for photoelectric sensors) and discrete or analog output. This flexibility allows a single sensor to be configured for a variety of applications.

DeviceNet sensors may be assigned any node address between 0 and 63. While a sensor's baud rate is determined automatically as it is added to the network (autobaud), it may also be manually programmed to 125, 250, or 500 kb/s. Configuration of all network and sensor parameters can be done over the network with

Rockwell Software's RSNetWorx™ package and for field configuration or diagnostics, the DeviceView™ Hand-Held Configurator (2707-DNC) is available.

**Features**

- Direct interface to DeviceNet network
- Strobing and COS protocols
- Autobaud detect
- Operating parameters configurable over the network
- Advanced diagnostics
- Integral timing and counting functions
- Mini, micro, or cable connection options

**DeviceNet Sensors**

RightSight™ DeviceNet . . . . page 10-4  
 SmartSight™ 9000 . . . . . page 10-8  
 Inductive Proximity  
 DeviceNet . . . . . page 10-12  
 Limit Switch DeviceNet . . . . page 10-14  
 Encoder DeviceNet . . . . . page 10-16



DeviceNet RightSight

### Description

RightSight DeviceNet photoelectric sensors interface directly to this industry standard plant floor network without the need for additional I/O blocks or adaptors.

### Features

- Compact RightSight housing
- 1200 psi (8270 kPa) washdown rating
- Direct interface to DeviceNet network
- Strobing and COS protocols
- On Delay and Off Delay/One-Shot timers
- Adjustable counter with output
- Adjustable motion detection
- Dual margin threshold diagnostics
- Autobaud

### Specifications

Environmental	
Certifications	UL Listed, CSA Certified, and CE Marked for all applicable directives
Operating Environment	NEMA 4X, 6P; IP67 (IEC 529) 1200 psi (8270 kPa) washdown, IP69K
Operating Temperature [C (F)]	-25...+70° (-13...+158°)
Vibration	10...55 Hz, 1 mm amplitude, meets or exceeds IEC 60947-5-2
Shock	30 g with 1 ms pulse duration, meets or exceeds IEC 60947-5-2
Relative Humidity	5...95% (noncondensing)
Ambient Light Immunity	Incandescent light 5000 lux
Optical	
Sensing Modes	Polarized retro, diffuse, sharp cutoff diffuse, background suppression, fiber optic, transmitted beam
Sensing Range	See Product Selection table
Field of View	
Light Source	Visible red (660 nm), infrared (880 nm)
Operation Mode	Selectable light or dark operate
LED Indicator	See User Interface
Adjustments	Potentiometer for diffuse, sharp cutoff and fiber optic models only
Electrical	
Voltage	11...25V DC
Current Consumption	65 mA max
Sensor Protection	Miswire, hot insertion
Communications	
Response Time	3 ms (11 ms for transmitted beam models)
Network Interface Type	DeviceNet
Messaging Type	Selectable change-of-state (COS) and strobing
Autobaud Detect	Selectable on/off
Communication Rate	Selectable 125 kb/s, 250 kb/s, 500 kb/s or autobaud
Node Address	Selectable 0...63
Diagnostic Type	Selectable static or dynamic with dual thresholds (0.7...1.5 and 0.7...2.0)
Mechanical	
Housing Material	Mindel
Lens Material	Acrylic
Cover Material	Udel
Connection Types	5-pin micro (M12) QD
Supplied Accessories	18 mm mounting nut
Optional Accessories	Reflectors, cordsets, Rockwell Software RSNetwork for configuration

**User Interface**

Label	Color	State	Status
Output	Yellow	On	Target detected
Margin	Orange	Off	Margin < 2.0
		On	Margin > 2.0
Status	Red/Green	Off	Sensor not powered
		Green On Steady	Sensor active and allocated by a Master
		Green Flashing	Sensor active but not allocated by a Master
		Red Flashing	Minor correctable fault (baud rate)
		Red On Steady	Major fault (possible duplicate address)

**I/O Data Byte 1**

	Bit 0	Bit 1	Bit 2	Bit 3	Bit 4	Bit 5	Bit 6	Bit 7
	Sensor Output	Diagnostic	Diagnostic Margin 2x	Diagnostic Margin 3x	Motion Output	Counter Output	Not Used	Not Used
0	OFF	OK	OK	OK	Motion	Less Than Preset		
1	ON	ALARM	Margin Unstable	Margin Unstable	No Motion	Preset Reached		

**RightSight Nonadjustable Sensor**  
 (Polarized retro and background suppression models only)

**RightSight Adjustable Sensor**  
 (Diffuse, sharp cutoff and fiber optic models only)

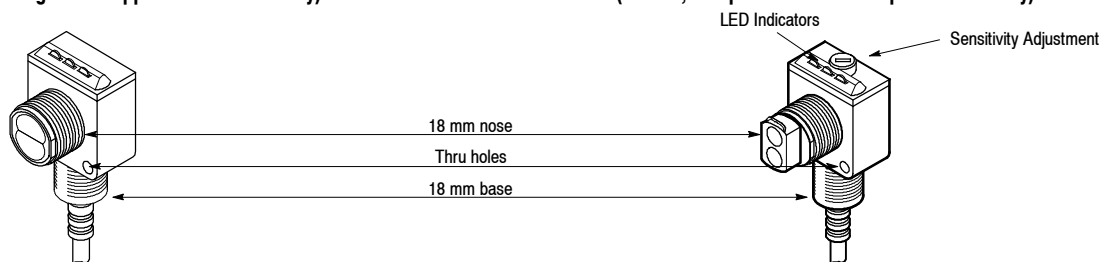

**Approximate Dimensions [mm (in.)]**

**DeviceNet Models**

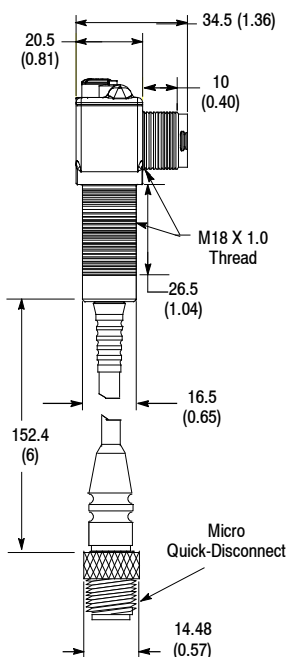

**DC Light Source Models**

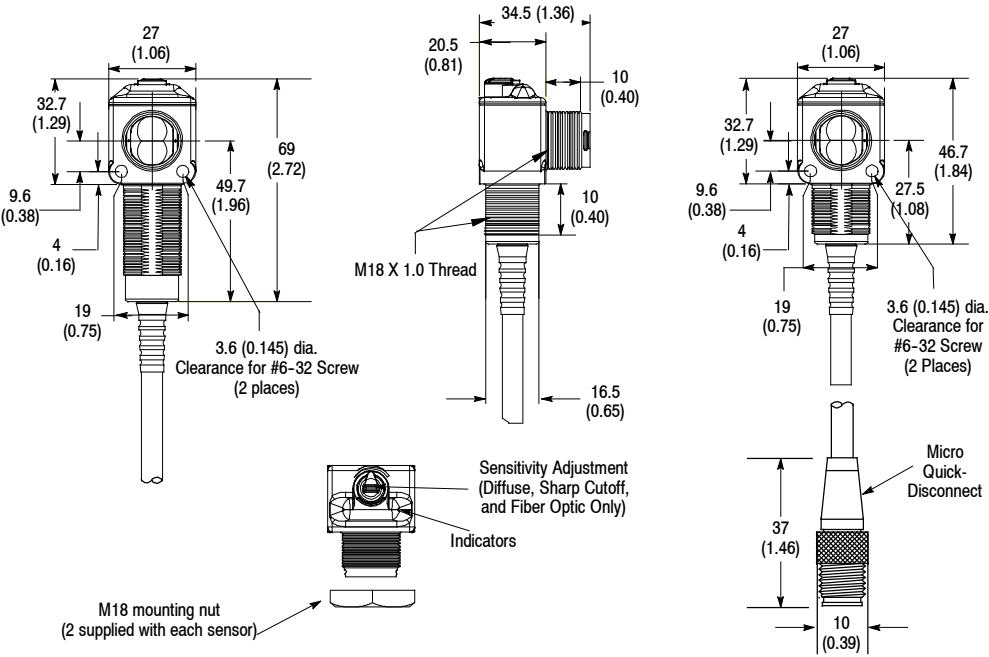

Product Selection

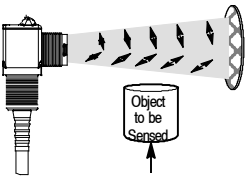
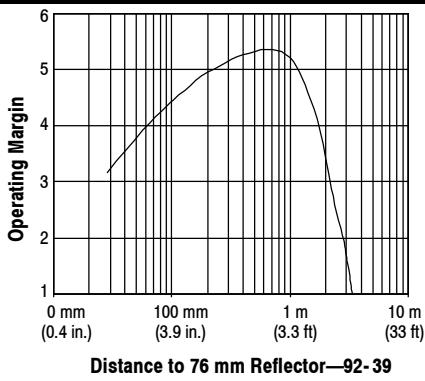
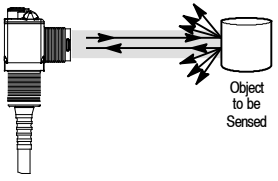
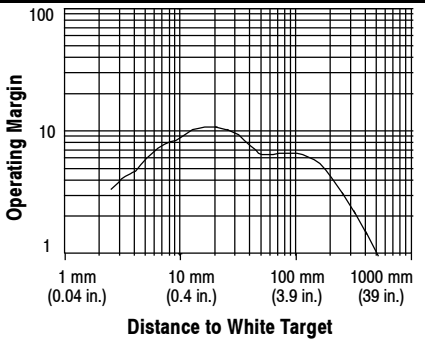
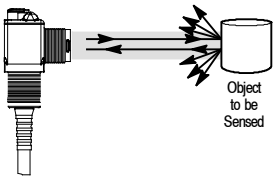
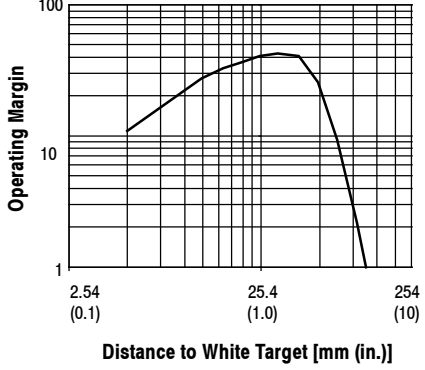
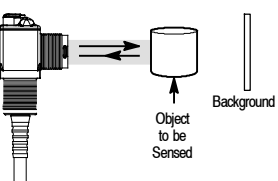
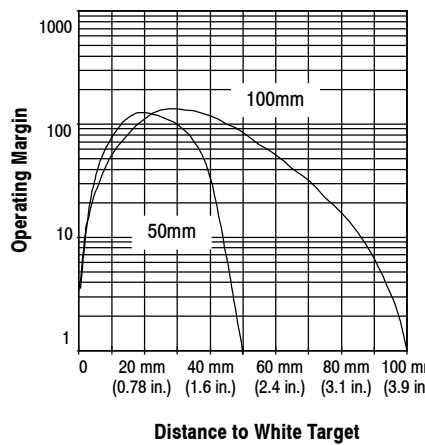
Sensing Mode	Min/Max Sensing Distance	Connection Type	Cat. No.	Typical Response Curve
 <p><i>Polarized Retroreflective</i>  <b>Field of View:</b> 1.5°  <b>Light Source:</b> Visible red 660 nm</p>	25 mm (1.0 in.)/ 3 m (9.8 ft)	5-pin DC micro QD	42EF-P2LDB-F5	 <p><b>Distance to 76 mm Reflector—92-39</b></p>
 <p><i>Standard Diffuse</i>  <b>Field of View:</b> 5°  <b>Light Source:</b> Infrared 880 nm</p>	3 mm (0.12 in.)/ 500 mm (20 in.)		42EF-D1LDAK-F5	 <p><b>Distance to White Target</b></p>
 <p><i>Sharp Cutoff Diffuse</i>  <b>Field of View:</b> 7°  <b>Light Source:</b> Infrared 880 nm</p>	<130 mm (5 in.) 40 mm (1.5 in.) @ 30x margin		42EF-S1LDA-F5	 <p><b>Distance to White Target [mm (in.)]</b></p>
 <p><i>Background Suppression</i>  <b>Field of View:</b> 20° (50 mm models) 8° (100 mm models)  <b>Light Source:</b> Infrared 880 nm</p>	3 mm (0.12 in.)/ 50 mm (2 in.)		42EF-B1LDBC-F5	 <p><b>Distance to White Target</b></p>
	3 mm (0.12 in.)/ 100 mm (4 in.)	42EF-B1LDBE-F5		

**Product Selection (continued)**

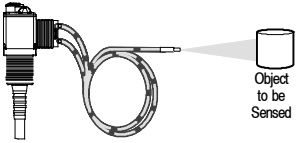
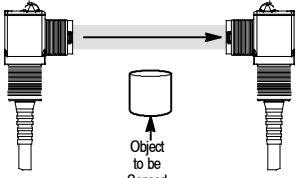
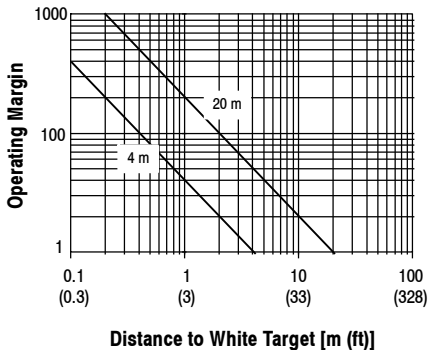
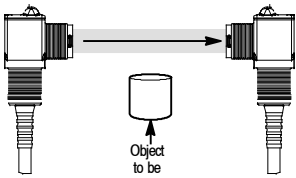
Sensing Mode	Min/Max Sensing Distance	Connection Type	Cat. No.	Typical Response Curve
 <p><i>Large Aperture Glass Fiber Optic</i>  <b>Light Source:</b> Infrared 880 nm</p>	Depends on fiber optic cable selected	5-pin DC micro QD	42EF-G1LDA-F5	Depends on fiber optic cable selected. See page 1-235 for fiber optic cable selection.
 <p><i>Transmitted Beam</i>  <b>Light Source:</b> Infrared 880 nm</p>	See receiver models below	5-pin DC micro QD	42EF-E1EDZB-F5	 <p><b>Operating Margin</b></p> <p><b>Distance to White Target [m (ft)]</b></p>
		4-pin DC micro QD	42EF-E1EZB-F4	
		2m 300V cable	42EF-E1EZB-A2	
 <p><i>Transmitter Beam Receiver</i>  <b>Field of View:</b> 7°</p>	25 mm (1 in.)/ 4 m (13 ft)	5-pin DC micro QD	42EF-R9LDBV-F5	
	25 mm (1 in.)/ 20 m (60 ft)		42EF-R9LDB-F5	

**Accessories**

Description	Cat. No.
Reflector, 76 mm (3 in.) diameter with center mount hole	92-39
Reflector, 32 mm (1.25 in.) diameter	92-47
Mounting bracket swivel/tilt	60-2649
2 m (6.5 ft) micro QD cordset	1485R-P2R5-C
2 m (6.5 ft) micro QD patchcord	1485R-P2R5-F5

For additional mounting brackets and accessories, see page 1-293.

Refer to [www.rockwellautomation.com/resources/eds](http://www.rockwellautomation.com/resources/eds) for EDS files.



### Description

SmartSight photoelectric sensors interface directly to this industry standard plant floor network without the need for additional I/O blocks or adaptors. They combine the benefits of the Series 9000 mechanical and optical package with the DeviceNet bus system.

### Features

- Local and remote self-teach operation
- 1200 psi washdown rating
- Selectable strobing and COS
- Low margin diagnostics
- Adjustable motion detect
- On delay and off delay one-shot
- Adjustable counter with output

### General Specifications

<b>Environmental</b>	
Certifications (Ordinary Locations)	cULus Listed and CE Marked for all applicable directives
Operating Environment	NEMA 3, 4X, 6P, 12, 13; IP67 (IEC 529) 1200 psi (8270 kPa) washdown, IP69K
Operating Temperature [C(F)]	-25...+70° (-13...+158°)
Vibration	10...55 Hz, 1 mm amplitude, meets or exceeds IEC 60947-5-2
Shock	30 g with 1 ms pulse duration, meets or exceeds IEC 60947-5-2
Relative Humidity	5...95% (noncondensing)
Ambient Light Immunity	Incandescent light 5000 lux
<b>Optical</b>	
Sensing Modes	Retroreflective, polarized retro, diffuse, clear object, transmitted beam
Sensing Range	See Product Selection table
Field of View	See Product Selection table
Light Source	Visible red (660 nm), infrared (880 nm)
Operation Mode	Selectable light operate or dark operate
LED Indicator	See table on page 10-9
Adjustments	Push button for sensitivity adjustments
<b>Electrical</b>	
Voltage	11...25V DC
Current Consumption	75 mA max
Sensor Protection	Miswire, hot insertion
<b>Communications</b>	
Response Time	3.5 ms
Network Interface Type	DeviceNet
Messaging Type	Selectable change-of-state (COS) and strobing
Autobaud Detect	Selectable on/off
Communication Rate	Selectable 125 kb/s, 250 kb/s, 500 kb/s or autobaud
Node Address	Selectable 0...63—via network or local switch
Diagnostic Type	Selectable static or dynamic with dual thresholds (0.7...1.5 and 0.7...2.0)
<b>Mechanical</b>	
Housing Material	Valox®
Lens Material	Acrylic
Cover Material	Neoprene
Connection Types	5-pin DC micro QD, 5-pin DC mini QD, 2 m (6.5 ft) drop cable
Supplied Accessories	129-130 mounting kit
Optional Accessories	Reflectors, cordsets, Rockwell Software RSNetWorx for configuration



**I/O Data**

	Bit 0	Bit 1	Bit 2	Bit 3	Bit 4	Bit 5	Bit 6	Bit 7
	<b>Sensor Output</b>	<b>Diagnostic</b>	<b>Diagnostic Margin 2X</b>	<b>Diagnostic Margin 3X</b>	<b>Motion Output</b>	<b>Counter Output</b>	<b>Not Used</b>	<b>Not Used</b>
0	OFF	OK	OK	OK	Motion	Less Than Preset		
1	ON	ALARM	Margin Unstable	Margin Unstable	No Motion	Preset Reached		

**Indicators (refer to illustration)**

Label	Color	State	Status
Output	Yellow	ON	Target detected
Margin	Orange	OFF	Margin < 2.0
		ON	Margin ≥ 2.0
Status	Red/Green	OFF	Sensor not powered or auto baud
		Green ON Steady	Sensor active and allocated by master
		Green Flashing	Sensor active but not allocated by master
		Red Flashing	Minor correctable fault (baud rate)
		Red ON Steady	Major fault (possible duplicate address)

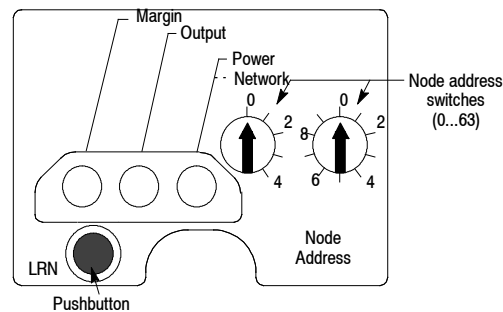

**NOTE:** LED indicators are used during the *Self-Teach* operation of the sensor. Refer to publication 1000002281 for complete instructions on using this feature.

**Approximate Dimensions [mm (inches)]**

**All Models Except ClearSight**

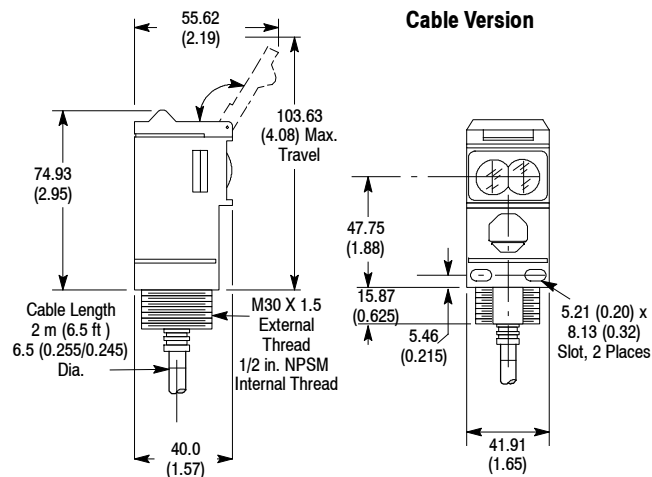

**ClearSight Models**

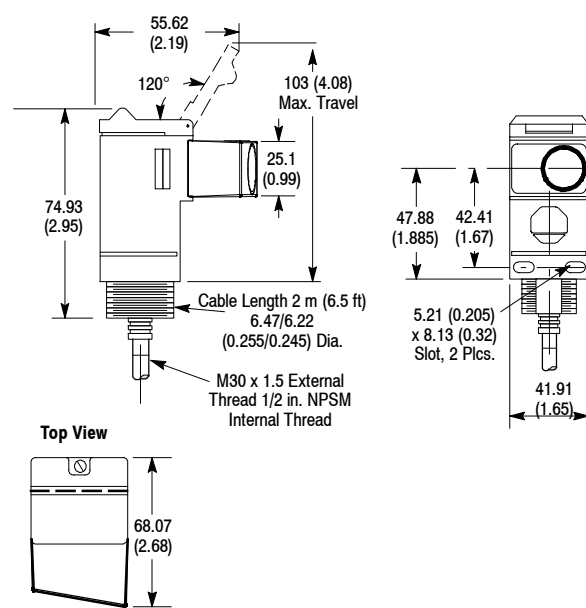

**Connector Version**



**Thread Size**

Micro Style	M12 x 1 1 Keyway
Mini Style	7/8-16 UN 1 Keyway

Product Selection

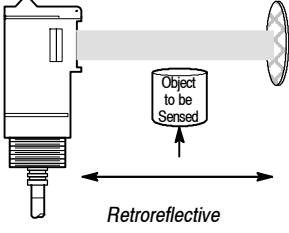
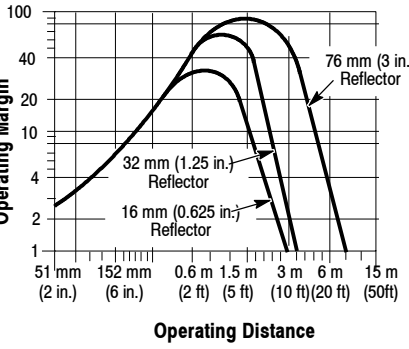
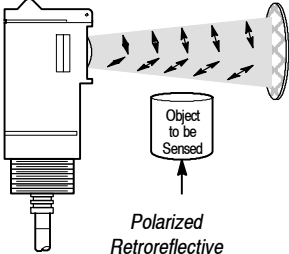
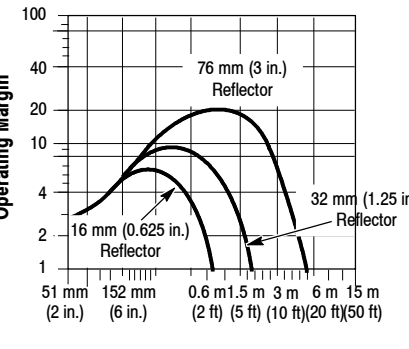
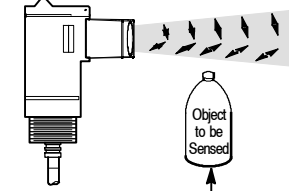
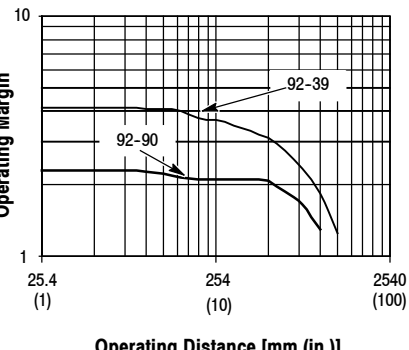
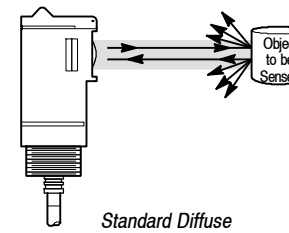
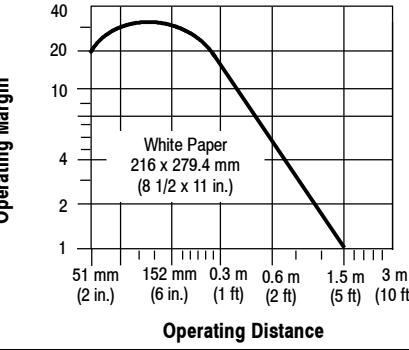
Sensing Mode	Min/Max Sensing Distance	Connection Type	Cat. No.	Typical Response Curve
 <p><b>Retroreflective</b></p> <p>Field of View: 1.5° Light Source: Visible red 660 nm</p>	51 mm (2 in.) 9.14 m (30 ft) with 76 mm (3 in.) Reflector	2 m CPE cable	42GNU-9020	
		5-pin DC micro QD	42GNU-9020-QD	
		5-pin mini QD	42GNU-9020-QD1	
 <p><b>Polarized Retroreflective</b></p> <p>Field of View: 1.5° Light Source: Visible red 660 nm</p>	51 mm (2 in.) 4.87 m (16 ft) with 76 mm (3 in.) Reflector	2 m CPE cable	42GNU-9220	
		5-pin DC micro QD	42GNU-9220-QD	
		5-pin mini QD	42GNU-9220-QD1	
 <p><b>ClearSight™</b></p> <p>Field of View: 1.5° Light Source: Visible red 660 nm</p>	0...1200 mm (0...48 in.)	2 m CPE cable	42GNC-9220	
		5-pin DC micro QD	42GNC-9220-QD	
		5-pin mini QD	42GNC-9220-QD1	
 <p><b>Standard Diffuse</b></p> <p>Field of View: 3.5° Light Source: Infrared 880 nm</p>	50.8 mm (2 in.) 1.52 m (5 ft) to White Paper	2 m CPE cable	42GNP-9020	
		5-pin DC micro QD	42GNP-9020-QD	
		5-pin mini QD	42GNP-9020-QD1	

**Product Selection (continued)**

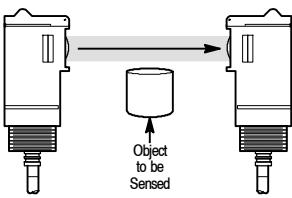
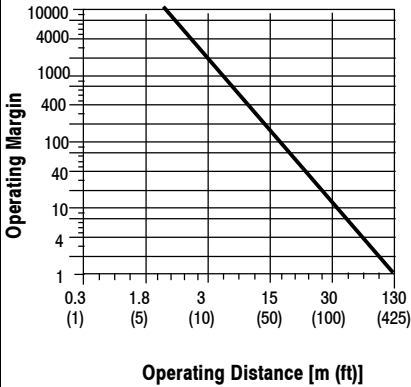
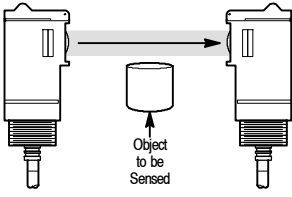
Sensing Mode	Min/Max Sensing Distance	Connection Type	Cat. No.	Typical Response Curve
 <p><i>Transmitted Beam</i>  <b>Field of View: 1.5°</b>  <b>Light Source: Infrared 880 nm</b></p>	130 m (425 ft)	5-pin DC micro QD	42GNL-9040-QD	
		5-pin DC mini QD	42GNL-9040-QD1	
 <p><i>Transmitted Beam Receiver</i></p>	130 m (425 ft)	2 m CPE cable	42GNR-9020	
		5-pin DC micro QD	42GNR-9020-QD	
		5-pin mini QD	42GNR-9020-QD1	

**Accessories**

Description	Cat. No.	Description	Cat. No.
Reflector, 76 mm (3 in.) Diameter with Center Mount Hole	92-39	Mounting Bracket Swivel/Tilt (nonClearSight models)	60-2439
Reflector, 32 mm (1.25 in.) Diameter	92-47	Mounting Bracket Swivel/Tilt (ClearSight models)	60-2681

Refer to [www.rockwellautomation.com/resources/eds](http://www.rockwellautomation.com/resources/eds) for EDS files.

# 871TM DeviceNet Sensors

## Inductive Proximity Sensors



871TM DeviceNet Cable Style  
18, 30 mm  
page 10-13



871TM DeviceNet Mini  
Quick-Disconnect Style  
18, 30 mm  
page 10-13



871TM DeviceNet Micro  
Quick-Disconnect Style  
18, 30 mm  
page 10-13

### Specifications

Current Drain	≤60 mA
Operating Voltage	11...25V DC
Repeatability	≤1% at constant temperature
Hysteresis	10% typical
Approvals	UL Listed, cUL Certified, and CE Marked for all applicable directives
Enclosure	NEMA 1, 2, 3, 3R, 4, 4X, 6, 6P, 12, 13; IP67 (IEC 529), 1200 psi (8270 kPa) washdown Stainless steel face and barrel
Connections	Cable: 2 m (6.5 ft) length Quick-Disconnect: 5-pin mini style 5-pin micro style
LEDs	Bicolor Red/Green: DeviceNet Network/Status Amber: Output energized
Operating Temperature [mm (in.)]	-25...+70° (-13...+158°)
Shock	30 g, 11 ms
Vibration	55 Hz, 1 mm amplitude, 3 planes

### Correction Factors

Target Material	Correction Factor
Steel	1.0
Stainless Steel	0.9...1.0
Brass	0.3...0.5
Aluminum	0.1...0.4
Aluminum ≤0.020 Thick	0.9...1.1
Copper	0.4...0.6

### Indicators (refer to illustration)

Label	Color	State	Status
Output	Yellow	On	Target detected
Status	Red/Green	Off	Sensor not powered
		Green On Steady	Sensor active and allocated by a Master
		Green Flashing	Sensor active but not allocated by a Master
		Red Flashing	Minor correctable fault (baud rate)
		Red On Steady	Major fault (possible duplicate address)

### Features

- Connects directly to DeviceNet networks
- Autobaud
- Discrete and analog output
- Diagnostic capabilities available
  - Object too close
  - Sensor operational
  - Object too far
- Timing functions: On, Off, and One-Shot Delay configuration
- Configurable normally open/normally closed
- Motion detection
- Teach/learn target capabilities
- UL Listed, cUL Certified, and CE Marked for all applicable directives

### I/O Data

Strobe and Change-of-State Output:

Byte 1	Bit 0	Bit 1	Bit 2	Bit 3	Bit 4	Bit 5	Bit 6	Bit 7
Sensor Output	Diagnostics	Coil Operational	Too Close	Too Far	Always In	Motion Detect	Counter Output	
Byte 2	Bit 0	Bit 1	Bit 2	Bit 3	Bit 4	Bit 5	Bit 6	Bit 7
Analog Output (Strobe Only)								

### Product Selection

Barrel Dia.	Nominal Sensing Distance [mm (in.)]	Shielded	Output Configuration	Cat. No.		
				Cable Style	Mini QD Style	Micro QD Style
18 mm	5 (0.20)	Y	Programmable N.O./N.C.	871TM-D5ED18-S2	871TM-D5ED18-N5	871TM-D5ED18-D5
	8 (0.31)	N		871TM-D8ED18-S2	871TM-D8ED18-N5	871TM-D8ED18-D5
30 mm	10 (0.39)	Y		871TM-D10ED30-S2	871TM-D10ED30-N5	871TM-D10ED30-D5
	15 (0.59)	N		871TM-D15ED30-S2	871TM-D15ED30-N5	871TM-D15ED30-D5

### Accessories

Description	Page Number
Terminal Chambers	8-1
Mounting Brackets	2-210...2-214
End Caps	2-219, 2-220
Mounting Nuts	2-221...2-222

### Approximate Dimensions [mm (in.)]

#### Cable Style

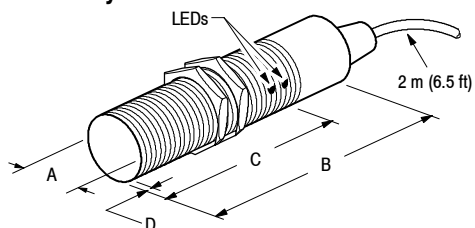

		Cable Style			
Thread Size	Shielded	mm (inches)			
		A	B	C	D
M18 x 1	Y	18.0 (0.71)	74.7 (2.94)	60.0 (2.36)	2.5 (0.10)
	N			48.2 (1.90)	14.4 (0.56)
M30 x 1.5	Y	30.0 (1.18)	77.2 (3.04)	61.3 (2.41)	2.5 (0.10)
	N			41.6 (1.64)	17.9 (0.70)

#### Mini QD Style

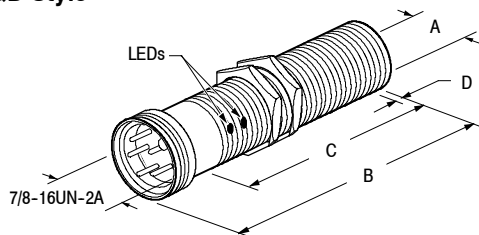

#### Micro QD Style

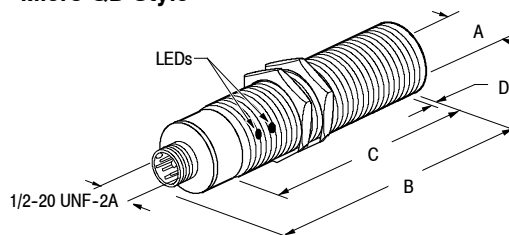

Mini QD Style						Micro QD Style					
Thread Size	Shielded	mm (inches)				Thread Size	Shielded	mm (inches)			
		A	B	C	D			A	B	C	D
M18 X 1	Y	18.0 (0.71)	76.6 (3.02)	54.9 (2.16)	2.5 (0.10)	M18 X 1	Y	18.0 (0.71)	84.3 (3.32)	60.0 (2.36)	2.5 (0.10)
	N			43.1 (1.70)	14.4 (0.56)		N			48.2 (1.90)	14.4 (0.56)
M30 X 1.5	Y	30.0 (1.18)	86.4 (3.40)	61.3 (2.41)	2.5 (0.10)	M30 X 1.5	Y	30.0 (1.18)	85.7 (3.37)	61.3 (2.41)	2.5 (0.10)
	N			41.6 (1.64)	17.9 (0.70)		N			46.1 (1.81)	17.9 (0.70)

## 802DN Lever Type with DeviceNet Output • Spring Return

### NonPlug-In Style Oiltight Limit Switches



NonPlug-In Style  
802DN-AD5 without  
Lever

### Description

Bulletin 802DN DeviceNet limit switches have been designed with the same rugged features of our 802T NEMA limit switches with the features and benefits of DeviceNet built in. These limit switches utilize DeviceNet technology to address the primary customer needs. The three most common needs are increased information flow, an inexpensive way to connect limit switches to a DeviceNet network, and reduction of down time by using the advanced diagnostic capabilities only available through DeviceNet. 802DN limit switches are configured using RSNetWorx for DeviceNet. Online configuration help is available using the parameter help feature.

### Features

- Direct connection to DeviceNet network
- Autobaud
- Dual outputs with distinct programmable angles to operate
- Teach and learn angle
- Each output programmable to N.O. or N.C.
- Programmable travel to reset (hysteresis)
- Configurable counters with resets on each output

### Specifications

Enclosure Rating	NEMA 1, 4, 6P, 13; IP67 (IEC 529)
Certifications	UL Listed, CSA Certified, and CE Marked for applicable directives
Ambient Temperature [C (F)]	NonPlug-In limit switches are designed to operate in an ambient temperature range of -18...+54° (0...+130°)

### Features (continued)

- Multiple timing functions
  - Programmable in 1 ms increments
    - On delay timer
    - Off delay timer
    - One shot timer
- User-selectable discrete or analog output
- Multiple maintenance warnings
  - Overtravel alarm
  - Motion detection
  - Slow lever return alarm
  - Jam detect
- User defined counter preset used for Tracking total operations and maintenance alarming
- Supports change-of-state (COS) or strobing protocol

### High Degree of Versatility

Bulletin 802DN limit switches can be mounted in any position, with operating heads that can be rotated and fastened in any one of four positions 90° apart. Most operating levers are interchangeable and can be rotated and clamped in any position through 360°.

### NEMA Type 13 Construction

802DN limit switches feature NEMA Type 13 construction with synthetic rubber seals to protect the operating parts against entry of oil, dust, abrasives, water and coolant, within the limits of NEMA-specified tests.

### Easy Mounting and Wiring

Each switch base has four mounting holes: two “through” holes for front mounting and two tapped holes in the back for rear mounting. Three different wiring styles are available for ease of installation. Each of the models is available for order with one of the following: a five-pin micro quick-disconnect, a five-pin mini quick-disconnect, or a prewired two meter cable.

### Lever Type Switches

These switches are operated by means of a lever that is clamped to a knurled shaft extending from the operating head.

Lever type switches can be equipped with a variety of operating levers: roller lever, adjustable roller lever, micrometer adjustment roller lever, rod lever, one-way rod or roller lever and fork lever. These can be used interchangeably on all lever type switches.

The micrometer adjustment roller lever, Cat. No. **802T-W6**, is designed especially for installations where the exact position of the roller is critical. This lever has a pivoted roller which can be turned laterally. After clamping the lever to the switch shaft, the position of the roller can be precisely adjusted through an arc of 7.5° on either side of the center or straight-line position.

### Wide Belt Roller

The **802DN-WBR-XX** limit switches come packaged with a special lever arm. This limit switch has been specifically designed for precise position detection of conveyor belts. By using the advanced features of DeviceNet, this limit switch is ideal for this application.

### Operating Levers

See pages 6-91...6-96.

# 802DN Lever Type with DeviceNet Output • Spring Return

## NonPlug-In Style Oiltight Limit Switches

### Range of Operation

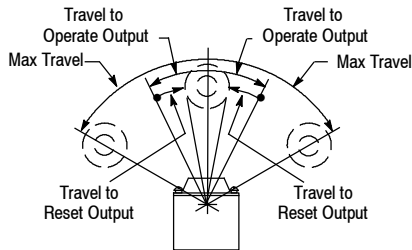

Switch  
Without Lever

### Product Selection

Lever Movement	Torque to Operate (Max)	Travel to Operate Output #1	Travel to Operate Output #2	Max Travel	Travel to Reset	Lever	Connection Type	Cat. No.
Clockwise or Counterclockwise	0.34 N•m (3 lb•in.)	Programmable	Programmable	54°	Programmable (5° min)	None	2 m cable	802DN-AS2
							5-pin mini	802DN-AN5
							5-pin micro	802DN-AD5
						Wide belt roller	2 m cable	802DN-WBRS2
							5-pin mini	802DN-WBRN5
5-pin micro	802DN-WBRD5							

### I/O Data

Byte 1								Byte 2							
Bit 0	Bit 1	Bit 2	Bit 3	Bit 4	Bit 5	Bit 6	Bit 7	Bit 0	Bit 1	Bit 2	Bit 3	Bit 4	Bit 5	Bit 6	Bit 7
Output 1	Output 2	Maintenance Diagnostic	Over Travel	Slow Return	Counter 1 Output	Counter 2 Output	Not Used	Analog Output (Strobe Only)							

Outputs 1 and 2 are programmable N.O./N.C.  
See electronic data sheet for programming instructions.

### Approximate Dimensions [mm (in.)]

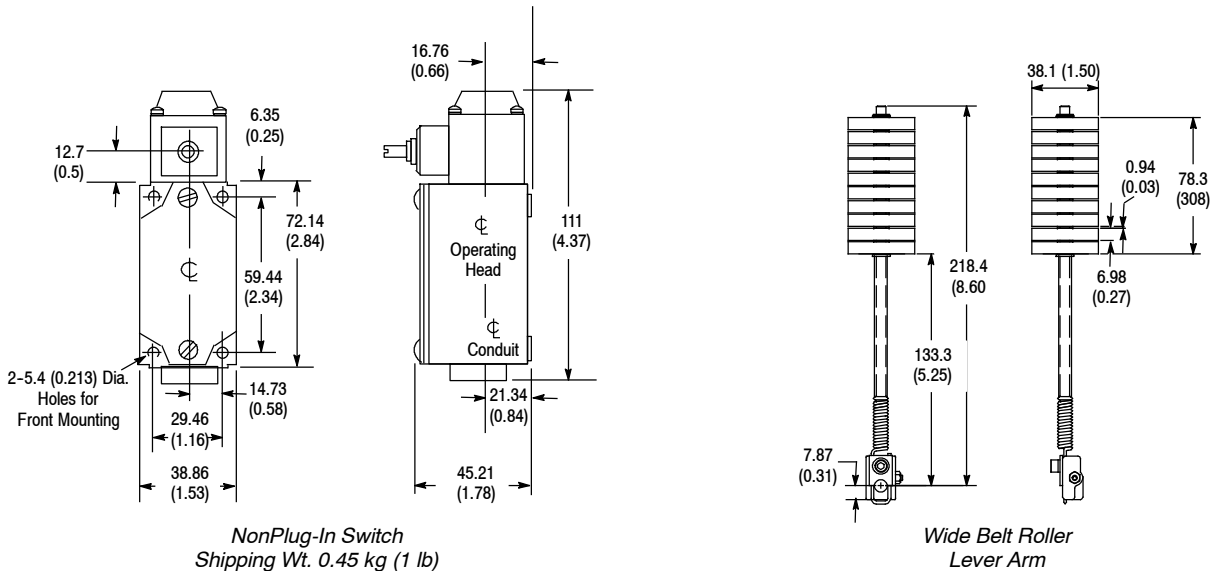

# Bulletin 842D DeviceNet Absolute Multi-Turn Magnetic Encoder



DeviceNet Encoder

## Description

The Bulletin 842D offers direct connection to DeviceNet for advanced functionality with reduced wiring cost. The following is a partial feature list:

## Features

- Magnetic design withstands 100 g shock and temperature extremes
- 26 bit multi-turn absolute encoder retains position data if power is lost
- Up to 8192 PPR & 8192 turns
- Connects via 5-pin micro QD
- Slotted rear cover allows address and baud rate selection
- Position reset button
- NEMA 4/IP66 housing

## Programmable Features

- Current position (0 to 67,108,864)
- Counts per revolution (1 to 8192)
- Revolutions (1 to 8192)
- Eight programmable cams with high/low limits & hysteresis
- Position change required for COS communication
- Counting direction (cw/ccw)

## Diagnostic Features

- Red and green LEDs
- Cumulative operating time
- Min./max. acceleration & velocity
- Maximum velocity warning flag
- Current velocity (RPM, RPS or STEPS/SEC)

## Specifications

Electrical	
Code Format	Natural binary
Code Direction	CW or CCW (programmable)
Electrical Interface	DeviceNet specification release 2.0
Operating Voltage	11...25V DC (24V DC recommended)
Power Requirements	1.8 W
Max # of Steps/Revolution	8192
Max # of Revolutions	8192
Position Forming Time	0.3 ms
Delay on Power Up	1050 ms
Preset Position	Via covered rear button or DeviceNet
Mechanical	
Angular Acceleration	$5 \times 10^5 \text{ rad/s}^2$
Moment of Inertia	$35 \text{ gcm}^2 (5.0 \times 10^{-4} \text{ oz}\cdot\text{in}\cdot\text{s}^2)$
Operating Speed	6000 RPM at max shaft loading
Starting Torque	$2.5 \text{ N}\cdot\text{cm} (3.5 \text{ oz}\cdot\text{in})$
Shaft Loading	Axial 11 lb (50 N) Radial 67 lb (300 N)
Environmental	
Housing	Aluminum
Operating Temperature [C (F)]	-20...85° (-4...+185°)
Storage Temperature [C (F)]	-40...125° (-40...+257°)
Humidity	98% noncondensing
Enclosure Type Rating	NEMA Type 4, 13, IP66 (IEC 529)
Shock	100 g/6 ms
Vibration	20g/10...2000 Hz
Approximate Weight [kg (lbs)]	0.91 (2)

## Accessories

Description	Page Number
Flexible Couplings	6-47
Servo Clamps	6-48
Mating Connectors	8-24 ①
Mounting Plates	6-52

## Indicators

LED	Status
Off	Not connected not on-line
Green Blinking	Active but not allocated by master
Green Steady	Active and allocated by master
Red Blinking	Minor fault and/or connection interrupt
Red Steady	Critical communication fault

① Also see DeviceNet round media cable in the Network Media section of the *On-Machine™ Connectivity* catalog.





Notes

---